

## Development in Sub-Saharan Africa: Overcoming the Digital Divide

Oyedokun Agbeja and R.O. Salawu

Department of Management and Accounting, Obafemi Awolowo University, Ile-Ife, Nigeria

---

**Abstract:** In an increasingly digitalized world economy, there exists a digital gap between Sub-Saharan Africa and the rest of the world that translates into economic marginalization of the African region. Consequently, the following phases of development are crucial for the region: (1) the phase of massive digitalization during which the digital divide is bridged and (2) the phase of information and knowledge management in which information is systematically converted into knowledge and the latter into innovative-sustainable development. Information for conversion into knowledge is supplied by the first phase. The second phase is therefore existence dependent on the first. Therefore, the attainment of digitalized state is primary-sine qua non. The envisaged digitalized state can be actualized and consolidated with a combination of: (a) curriculum in computer education consisting of computer taxonomy, networking and ICT<sub>s</sub> in general for secondary and tertiary institutions but also aptly adoptable for informal groups and (b) establishment of multipurpose telecentres in rural areas and a diffusion of networks in urban centres. Once a steady digitalized state evidenced by uninterrupted connectivity to the internet is attained, the second phase can be realized. Without steady supply of electricity, however, sustainable development and competitive edge may be hard to come by in a world of fierce competition.

**Key words:** Digitalization, spatial, geographic, networking, computer taxonomy, telecentres

---

### INTRODUCTION

For Sub-Saharan Africa, development is viewed as a process occurring in two stages: the phase of digitalization and the phase of information and knowledge management. The first is supposed to bridge the digital divide between the region and the rest of the world but may not necessarily overcome the region's economic marginalization. The second permits the cyclic process - information to knowledge conversion and knowledge to innovative development conversion and thus facilitating sustainable development. Phase two is existence dependent depending on existent and functioning digitalized state. Achieving this digitalized state in Sub-Saharan Africa is the aim of this study.

### THE ENVIRONMENT OF CURRENT GLOBALIZATION

Through its processing, storing, computational and communications capabilities, the digital computer is transforming the world economy revolutionarily in a manner never before experienced in the history of man. The digital computer has reduced the world to a global village in which territoriality is fast losing meaning and an electronically networked world economy has virtually emerged. In this digital age, geographically defined markets and states are disintegrating and world economy

is reintegrating in a very different a-spatial form through electronic networks in which fragments of individuals, groups and organizations are reassembled electronically in cyberspace. This digitally integrated world economy is variously described as information economy; knowledge economy; internet economy; networked economy; e-business; content economy and so on.

In the past, time and space were linked. Processes that required simultaneity in time also required spatial proximity. Economic activity was organized in terms of space of places (Castells, 1996). The information revolution has broken this time-space connection. Spatial proximity is no longer a requisite for simultaneous processing. For instance, a programmer physically present in Bangalore, India is simultaneously working on a computer in New York, USA via satellite. Castells (1996) argues that in our emerging networked society, space of places is being replaced by a space of digital (binary) flows of 0s and 1s. Thus, the network of communication is the fundamental spatial configuration: places do not disappear, but their logic and meaning become absorbed in the network (Castells, 1996). This argument does not apply to all economic activity. Space, territory and geographic markets retain meaning in many sectors. In others, space is losing importance and transactions and markets are moving to cyberspace. This is particularly true in economic activity which is information driven.

Capital markets including brokerage firms are information driven. Also, the financial sector-aggregate of banks, insurance organizations and finance houses is information driven. Banks are the drivers in the consummation of investments in equity and debt. Barter is extinct in an era of bank networking in which transactions are consummated even across national borders in real-time. Thus, international investors can rapidly invest in local industries without leaving the shores of their nations. The pre-requisite is that local financial assets, notably, shares and debts are investible. In turn, the requisite for investability is that on one hand, the local capital markets are sufficiently liberalized so that any clean individual on the globe can invest in local industries. On the other hand, the local capital markets and banking sectors must have the necessary infrastructure and facility to be part of international financial networking in which the participants share information, skills and even risk. When risk is shared, the cost of equity falls (Stulz, 1995, 1999). *Ceteris paribus*, the weighted average cost of capital is bound to favourably fall. Low cost of investment is a major attraction on the international market (Stulz, 1995).

**At the core of current globalization:** At the core of this phenomenal transformation- globalization, the computer assumes, inevitably, a unique preeminence. In the networked economy, the digital computer is always playing an indispensable role in one form or another. Fig. 1 is a taxonomy of computer by type, size and purpose.

Understanding this taxonomy is a requisite for the understanding of the workings and underpinnings of globalization especially networking and its attendant potential for development.

At point B the computer is completely analog and measures only continuous physical magnitudes such as voltage, temperature and pressure. At point A, the computer is fully digital and measures only discrete units. Between A and B, the computer is hybrid and combines the capabilities of both analog and digital.

The memory size of a digital computer could be as low as 4 kilobytes (micro computers) or as large as 120 Gigabytes (super large computers). Between these two extremes are mini, small, medium and large computers.

Irrespective of its memory size, a digital computer could serve as a general purpose, or special purpose, or scientific or business computer.

However, only micro (personal) and mini computers are usually dedicated to certain purpose(s)

**Dedicated computers:** A microcomputer or a minicomputer is usually committed or dedicated to a particular data processing task or application. For example, general

purpose computers of the micro and mini size variety are frequently dedicated to performing such jobs as data communications network control, database management, input/output control for larger computer systems, networked banking and automated manufacturing, to mention a few. As nodes on networks, they each perform a dedicated assignment assisting the central computer (server).

The Nodal Computer (PC) supported with peripheral devices such as monitor, keyboard and printer, *ceteris paribus*, can navigate the internet and download and print textual and non-textual materials on websites and other reservoirs of data and information. Cross communication between nodal PCS is achievable. In networking, the PC is a veritable tool. The PC powered by super softwares-windows is a veritable tool for accumulating large volumes of data/information from sources all over the globe at real time. Information is the source of knowledge. Knowledge development is a necessary requisite for innovative development. Any society that wants to grow and overcome poverty must be in the bandwagon of innovative development.

**Networking:** All networks involve the same basic principle: information can be sent to, shared with, passed on, or bypassed within a number of computer stations (nodes) and a master computer (server). Network applications include Local Area Networks (LANs), Metropolitan Area Networks (MANs), Wide Area Networks (WANs), System Area Networks (SANs), Intra and Inter building Communications, Broadcast Distribution, Intelligent transportation Systems (ITS), Telecommunications, Supervisory Control and Data Acquisition (TSCADA) networks and a host of others.

**Network topologies:** Networks can be configured in a number of topologies. These include a bus, with or without a backbone, a star network, a ring network, which can be redundant and/or self-healing, or some combination of these. Each topology has its strengths and weaknesses and some network types work better for one application while another application would use a different network type. LANs, MANs, or WANs generally use a combination, or mesh topology.

**Bus network:** A bus network topology is also called a daisy-chain topology. In this topology, each computer is directly connected on a main communication line. One end has a controller; the other end has a terminator. Any computer that wants to talk to the main computer must wait its turn for access to the transmission line. In a straight network topology, only one computer communicates at a time. When a computer uses the network, the information is sent to the controller, which

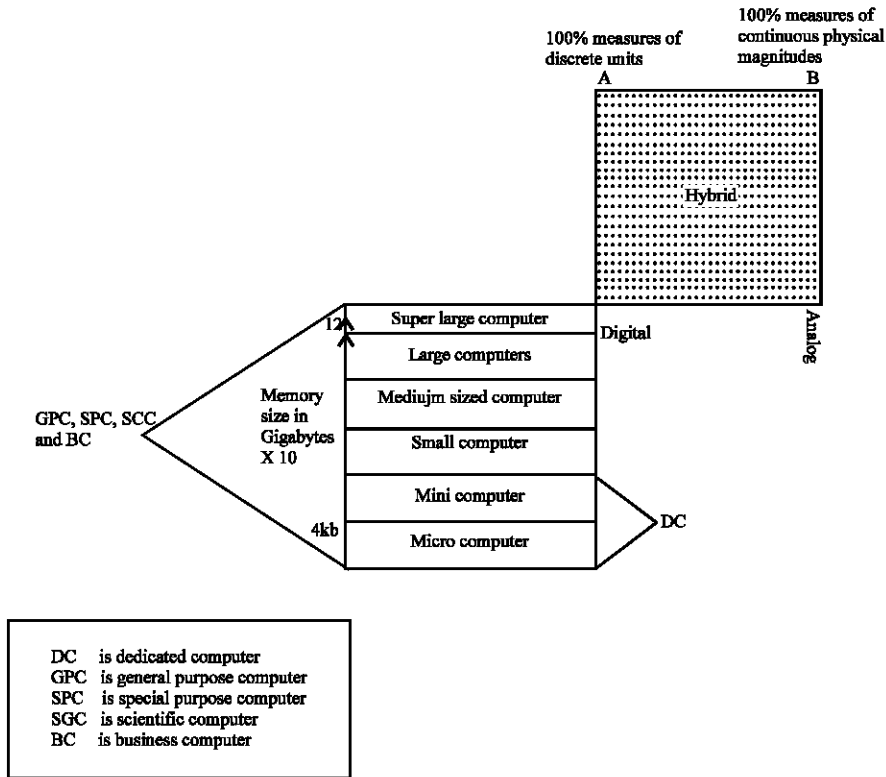

Fig. 1: A taxonomy of computer by type, size and purpose

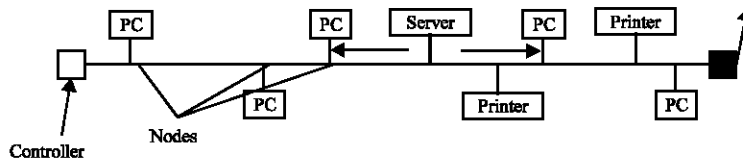

Fig. 2: BUS Network

then sends the information down the line of computers until it reaches the terminating computer. Only the computer or the peripheral on the network identified by the code with the message reads the latter. The purpose of the terminator at one end of the network is to prevent the signal from being reflected back. Fig. 2 depicts a simple bus network topology.

A bus network with a backbone operates in the same fashion but each computer has an individual connection to the network. A bus network with a backbone offers greater reliability than a simple bus topology. In a simple bus, if one computer in the network goes down, the network is broken. A backbone adds reliability in that the loss of one computer does not disrupt the entire network. Fig. 3 is a bus network topology with a backbone.

Star networks incorporate multipoint star couplers to achieve the topology. In a star network, all the nodes (PCs, printers and other shared peripherals) are connected

to the central server. As with the bus topology with a backbone, the failure of one computer node does not cause a failure in the network. Fig. 4 illustrates star network topology.

Both the bus and the star network topologies use a central computer that controls the system inputs and outputs. Also called a server, this computer has external connections, to the internet for example, as well as connections to the computer nodes in the network. It is quite easy to remove and add nodes. This topology can be more expensive than any other topologies. If the server goes down, no one can use the network.

All the nodes in a ring network are connected in a closed circle of cable (Fig. 5). Messages that are transmitted travel around the ring until they reach the computer that they are addressed to, the signal being refreshed by each node. There may or not be a file server.

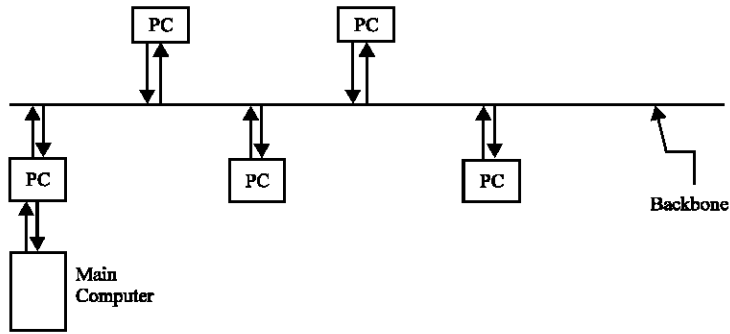

Fig. 3: BUS network with backbone

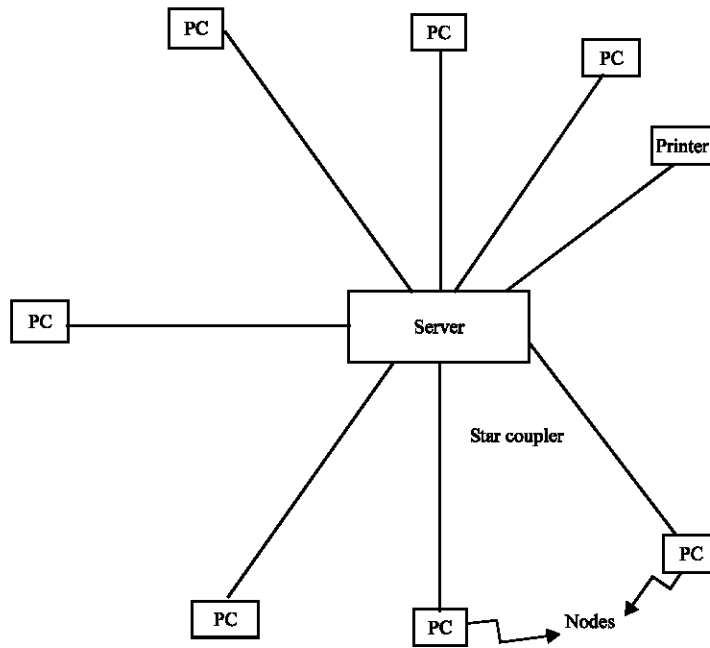
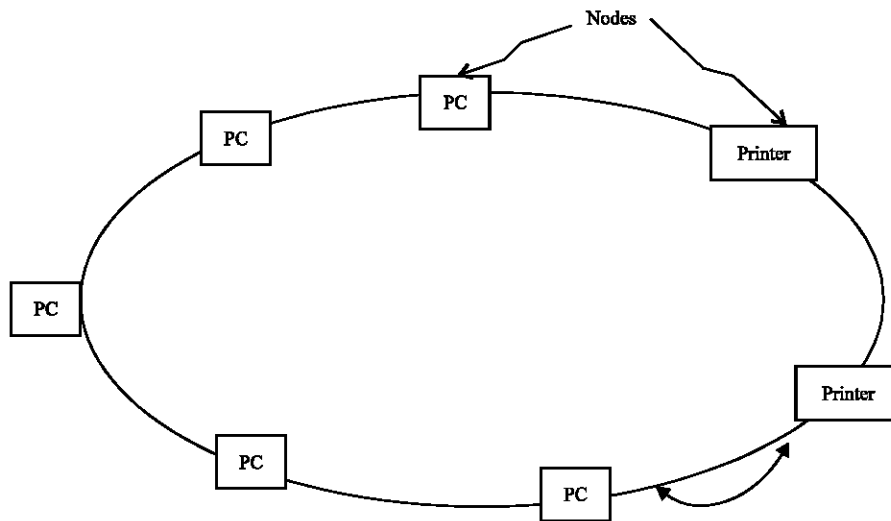

Fig. 4: Star network



Signals travel in both directions in newer ring networks

Fig. 5: Ring network

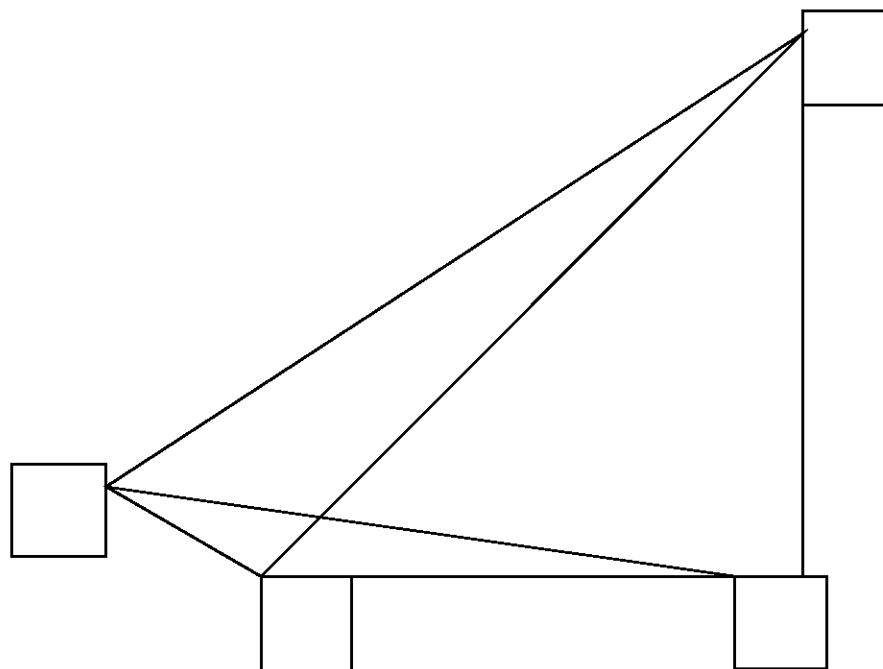

Fig. 6: Mesh network

The advantage of ring networks is that they can be larger than bus or star because the signal is regenerated by each node.

A disadvantage is that the network goes down if one node is inoperable. Data clashes can occur if two machines send messages at the same time. Tokens or electronic signals that travel around the ring were invented to solve the problem. In a token ring network, a computer can send a message when the token is with it at the time.

Every node on a mesh network is physically connected to every other node on the network. This provides a great deal of performance and reliability. However, the complexity and difficulty of creating one increases geometrically as the number of nodes on the network increase. For example, a three or four node mesh network is relatively easy to create, whereas it is impractical to set up a mesh network of 100 nodes, the number of interconnections would be so unwieldy and expensive that it would not worth the effort.

Mesh networks are not used much in LANs but are used in WANs where reliability is important and the number of sites being connected together is fairly small. Fig. 6 is an example of a four-node mesh network.

#### Network coverage (geographic space)

**LANs:** LAN is a computer network that spans a relatively small area. Most LANs are confined to a single building

or group of buildings. One LAN can be connected to other LANs over any distance via telephone lines and radio waves. A system of LANs, connected in this way is called a WAN. LANs Ethernet are the most common for PCS. There is a limit on the number of computers that can be attached to a single LAN. Users on LAN can cross communicate through e-mail or by engaging in chat sessions. Generally, LANs transfer data at very fast rates. In terms of transmission rate LANs are superior to telephone lines.

**MANs:** In terms of geographic breadth, MANs are larger than LANs, but smaller than WANs. MANs are usually characterized by very high speed connections.

**Connection media:** Nodes can be connected by twisted-pair wire, coaxial cables, or fibre optical cables. Some networks do without connecting media altogether, communicating instead via radio waves.

**The internet:** The internet is the largest network in the world for social, political and economic development. The internet which eminently represents a global peoples' network for communicating and sharing information consists of two powerful components or tools. These are the e-mail and the World Wide Web (WWW). The WWW is that part of the internet where a vast global information resource, or reservoir, or library has emerged

in recent years. The internet has become a vast and growing network that people use to converse, debate, meet, teach, learn. Buy and sell and share virtually every type of information imaginable. Currently, over 100 million computers are linked to the internet. In some countries, internet use is growing at a rate close to 1000% per year (FAO, 1996).

The internet together with several thousands of networks connected to it (internet) now constitutes the mega digitalized market. An electrically networked, virtual world economy is a reality. In this digitalized networked world economy, geography, including borders and territorial jurisdiction is becoming increasingly irrelevant (Kobrin, 1999). Emphasis has shifted from linkages within territorially defined national economies to relations between nodes in an a-geographic network; a network which can exist within cyber-rather than physical space (Kobrin, 1999).

**INTERNET POTENTIAL FOR DEVELOPMENT**

It is believed that the success of the internet in developed countries strongly suggests the global network has great potential for development purposes (FAO, 1996). The internet permits every user to be a sender, receiver, narrowcaster and broadcaster. In short, the internet offers opportunities for a two way and horizontal communication channels for urban based organizations, rural communities and development organizations.

According to the Food and Agricultural Organization (FAO), the internet has the following potential for rural development:

- Reduce the isolation and marginalization of rural communities;
- Facilitate dialogue among communities and those who influence them, such as government planners, development agencies, researchers, technical experts, educators and others;

- Encourage participation of communities in decisions which impact their lives by supporting bottom-up articulation of development needs and perceptions;
- Coordinate local, regional and national development efforts for increased efficiency and effectiveness;
- Help overcome the physical and financial barriers that prevent agricultural researchers, technicians, farmers and others from sharing information and competence; and
- Provide information, knowledge and skills training.

The Sub-Saharan African rural dwellers are poor, agrarian and have low literacy rate and inadequate health care. Therefore, the logical components of rural development in Sub-Saharan Africa are agriculture and food supply, education and health care. If rural development is internet driven, the above six potentials can be achieved.

(Of course, not at the exclusion of information and knowledge management). Then internet would have replaced famine with abundant food supply, illiteracy with literacy and poor health with sound health.

**THE DIGITAL DIVIDE**

According to the world internet usage and population statistics updated as at March 24, 2006, internet population penetration in Africa is 2.5% compared with the world average of 15.7%. Asia, Europe, Middle East, North America, Latin America/Caribbean and Oceania/Australia have internet population penetration of 9.9, 35.9, 9.6, 68.1, 14.3 and 52.9%, respectively. In terms of internet usage and penetration, Africa is at the bottom of the world. Evidently, there is a digital divide between Africa and the rest of the world (Table 1).

In the globalized digital economy, the internet is a major player. Unfortunately, rural areas of Sub-Saharan Africa lack the basic telecommunication infrastructure required for widespread internet access. Though the arrival of the digital mobile phone has eased the problem

Table 1: World internet users and population statistics  
World Internet Usage and Population Statistics

World Regions	Population (2005 Est.)	Population of world (%)	Internet usage, latest data	Population (penetration) (%)	Usage of world (%)
Africa	915,210,928	14.1	22,737,500	2.5	2.2
Asia	3,667,774,066	56.4	364,121,713	9.9	35.7
Europe	807,289,020	12.4	290,121,957	35.9	28.5
Middle East	190,084,161	2.9	18,203,500	9.6	1.8
North America	331,473,276	5.1	225,801,428	68.1	22.2
Latin America/Caribbean	553,908,632	8.5	79,033,597	14.3	7.8
Oceania/Australia	33,956,977	0.5	17,690,762	52.9	1.8
Total	6,499,697,060	100.0	1,018,057,389	15.7	100.0

Source: <http://www.internetworldstats.com/stats.htm>; downloaded: 24<sup>th</sup> March, 2006

of cross-communication between two individuals, it is no substitute for widespread internet access. The latter does not only permit cross-communication but also permits teleconferencing and downloading of large volumes of data and information. The latter when properly managed can produce knowledge. Knowledge, when prudently managed especially by sharing among community members can generate innovative ideas which can result in innovative development. Apart from the absence of basic infrastructure to facilitate networking in the rural areas, the average rural dweller cannot afford a PC. Therefore, the possibility of a rural dweller owning a nodal station on a local network is remote.

**Telecentres:** International and national development organizations are providing rural access to modern Information and Communication Technologies (ICTs) through telecentres. Telecentres are shared information and communication facilities in isolated rural communities where people neither have the skills to use modern ICTs nor afford to use them. Telecentres can provide access to telephone and fax services, e-mail, internet and digital networks, databases and libraries. Telecentres can also link the internet to local media such as radio and television. In this way, telecentre information is made accessible to wider audiences.

Telecentres were first used in Europe in the 1980s where the idea spread rapidly. Recently, some telecentre have been established in some semi-rural areas of Brazil. There is plan to spread the use of telecentres in the Latin American country in the next few years.

In order to meet all the components of rural development in Sub-Saharan Africa, a telecentre of the multipurpose variety in which tele-agriculture, tele-education and tele-medicine are terminals is desirable. In addition, the Sub-Saharan telecentres should also serve as facilities for organizing virtual village-to-village meetings and tele-training events. A Multipurpose Community Centre (MCT) is already underway in Uganda as pilot project (PP). The PP is to cover the Masaka, Rakai and Kalanga districts-a population of 1.2 million. By the time the PP is completed, it would have extended the existing networks using Digital Multi-Access Radio System (DMARS), small capacity radio systems and small capacity rural electronic exchanges with wireless access networks. In all, the PP anticipates 80 MCTs.

Policy makers in other countries of Sub-Saharan Africa might find it worthwhile to study the progress of the PP with a view to establishing similar MCTs in their own rural areas.

**Urban development:** In a digitalized world economy, urban areas of Sub-Saharan Africa need to increase their level of digitalization in order to further bridge the digital gap between Africa and the rest of the world.

If all surviving banks could also provide banking services on-line, manufacturing firms could advertise and promote sales of their products on websites and steadily on-line and all other service organizations are on websites and are able to render services steadily and on-line, then in terms of digitalization, urban centres including environs in Sub-Saharan Africa must have attained a status comparable to that existing in developed world.

**Computer education:** Computer education can also facilitate the closing of the digital divide. In this regard, it is suggested that the computer taxonomy, networking, network topologies, ICT, and Telecentres discussed above be used as curriculum in computer education at secondary and tertiary institutions. Uninterrupted supply of electricity is the challenge facing Sub-Saharan Africa. Local and international development policy makers should coherently strategize to overcome this challenge within a decade or so; they owe humanity this much. In the digitalized world economy, Sub-Saharan Africa gets on board now or risks being left behind for good (EIS-SSA,1999).

## CONCLUSIONS

In this digitalized global economy most economic activities and transactions especially those information driven are carried out via the internet. The digital divide (gap) between Sub-Saharan Africa and the rest of world translates, inescapably, into economic marginalization of the region. For development to take place in the region, the digital divide must first be bridged. In order to accomplish this first phase of development, the region must be effectively digitalized. Sub-Saharan Africa must be digitalized to an extent that the level of internet connectivity is comparable to the level existing in developed countries.

By establishing multipurpose telecentres in the rural areas of the region the rural dwellers can be effectively connected to the internet. Once browsing on the internet and intranets become banal within neighbourhoods and organizations, the region could be said to be fully prepared for the crucial phase of information and knowledge management. It is this latter phase that can guarantee sustainable development in education, health care and food production in the region. Irregular

supply of electricity is a major threat to development in Sub-Saharan Africa.

#### **REFERENCES**

- Castells, M., 1996. The rise of the networked society. The Information Age: Econ. Soc. Cult. Malden, M.A. Balckwell Publishers. Vol. 2.
- EIS-SSA, 1999. Emergent africa: Geo-information and globalization. The Africagis 1999 Conference, Accra, Ghana.
- Food and Agricultural Organization, 1996. Knowledge and information for food security in Africa. <http://www.Fao.org/docrep/w9290e03.htm>
- Kobrin, S.J., 1999. Development after industrialization: Poor countries in an Electrically integrated global economy working paper, The Wharton School, University of Pennsylvania.
- Stulz, R.M., 1995. Globalization and the benefits of international diversification. Bank of America. J. Applied Corporate Finance, Vol. 8.
- Stulz, R.M., 1999. Globalization and the cost of capital working paper 7021, National Bureau of Economic Research.