

# Transient Stability Improvement of Two Machine System using Fuzzy Controlled STATCOM

Surinder Chauhan, Vikram Chopra, Shakti Singh

**Abstract**— A static synchronous compensator is one of the FACTS devices used to improve the transient stability of the power system. In this paper a mamdani based fuzzy logic controller is designed. The inputs to the fuzzy logic are the alternator speed i.e.  $\omega$  and its derivative i.e.  $\frac{d\omega}{dt}$  and the output is the firing angle  $\alpha$  of the voltage source converter. The proposed controller is tested on two machine system using Matlab Simulink Environment. The Results are compared with conventional PI STATCOM Controller.

**Index Terms**— Transient Stability, FACTS, STATCOM, fuzzy logic controller.

## I. INTRODUCTION

Today Transmission & Distribution network of power systems are very stressed due to growing demand of better quality of power at lower cost. As a result transmission networks are operating on high transmission levels. Transient stability, damping oscillations etc are the major operating problems that power engineers are confronting during transmitting power at high levels. Transient Stability indicates the capability of the power system to maintain synchronism when subjected to a severe transient disturbances such as fault on heavily loaded lines, loss of a large load etc [1]. Generator excitation controller with only excitation control can improve transient stability for minor faults but it is not sufficient to maintain stability of system for large faults occur near to generator terminals [2]. Researchers worked on other solution and found that Flexible ac transmission systems (FACTS) is one of the most prominent solution that can improve stability by changing electrical characteristics of Power system [3],[4]. A static synchronous compensator is one of the FACTS device operated on principle of reactive power compensation can use to improve the transient stability of the system by increasing (decreasing) the power transfer capability when the machine angle increases (decreases) [5]. Static synchronous compensator's three modes i.e. capacitive mode, inductive mode and no load mode regulates voltage in transmission system. When Converter a.c. output voltage ( $V_c$ ) > transmission system voltage ( $V_s$ ), STATCOM considered to be in Capacitive mode and when  $V_s > V_c$ , STATCOM considered to be in inductive mode and in No-Load mode  $V_s = V_c$ , no reactive power exchange takes place [6]. STATCOM mainly

comprise of step down transformer with leakage reactance, three phase GTO voltage source inverter and a dc capacitor voltage [7]. Fig 1 shows equivalent circuit diagram of STATCOM system [8].

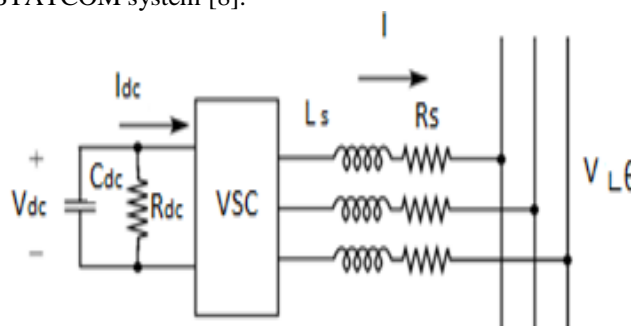

Fig 1. STATCOM's Basic circuit Diagram

Voltage across capacitor i.e.  $V_{dc}$  is given by following equation

$$C \frac{dV_{dc}}{dt} + GV_{dc} = mk[\sin(\alpha + \theta)I_D + \cos(\alpha + \theta)I_Q]$$

Where  $G$  is conductance across the capacitor that represented losses in the capacitor while  $\alpha$  and  $m$  are control variables of inverter which affected the magnitude and phase angle of the voltage injected by the inverter [9]. In STATCOM different technologies used dependent upon the power ratings of STATCOM. For higher power STATCOMs GTO based technologies are used while for lower power STATCOMs IGBT based technologies used [10]. In this paper GTO based technologies used. In GTO based static synchronous compensator  $m$  is normally kept constant and angle  $\alpha$  is varied to control reactive power [9]. Amount of real power generated or absorbed by STATCOM depends upon the size of capacitor. As compare to SVC, STATCOM provides a number of performance advantages for reactive power control applications because of its greater reactive current output capability at depressed voltage, faster response, better control stability, lower harmonics and small size etc [11],[12]. In This paper a mamdani based fuzzy logic controller is designed. The inputs to the fuzzy logic controller are the alternator speed and its derivative and output is firing angle  $\alpha$  of the voltage source converter. The proposed controller is tested on a two machine power system under Matlab Simulink Environment.

## II. TWO MACHINE SYSTEM

Fig 2 shows single line diagram of two area system (area 1 & area 2). Area1 (1000 MW hydraulic generation plant) connected to Area 2(5000 MW hydraulic generation Plant.) through 500 kV, 700 km transmission line.

**Manuscript received on March, 2013.**

Asst.Prof Surinder Chauhan, Electrical Engineering Department NIT Kurukshetra, Haryana,India.

Asst.Prof Vikram Chopra, EIED Deptt. Thapar University Patiala Punjab India.

Asst.Prof Shakti Singh, EIED Dept. Thapar University Patiala Punjab, India.

# Transient Stability Improvement of Two Machine System using Fuzzy Controlled STATCOM

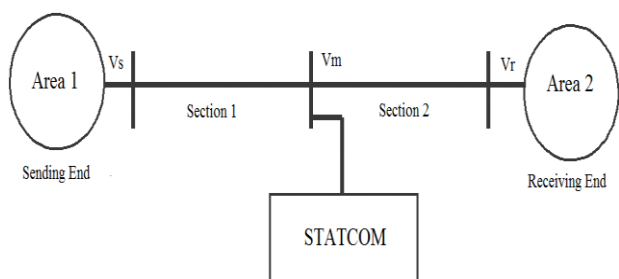

Fig 2. Single Line Diagram of Two Area Interconnected System

Both plants fed to a load center, modelled by a 5000 MW resistive load. System is initialized so that line carries 950 MW which is close to its surge impedance loading. In order to maintain system stability Static synchronous compensator of 200 MVA is connected at midpoint of transmission line. By connecting it at midpoint the power transfers capability of system increases significantly [13], [14].

### III. FUZZY LOGIC CONTROLLER

In Analytical approaches, Modelling and Control of Power Network requires mathematical equations/models. As power system models are highly non linear, number of assumptions need to be made before deriving mathematical equations [15]. Fuzzy Logic is one option by which one can get rid from above problem because fuzzy logic is technique which deals with human reasoning that can be programmed in to fuzzy logic language i.e. is membership function, rules interpretation [16]. Broadly fuzzy logic controller designed is classified in to following four states

- 1) Fuzzification
- 2) Knowledge base
- 3) Inference engine
- 4) Defuzzification.

Function of fuzzification is mapping of input of fuzzy logic i.e. is crisp value in to fuzzy variables by using membership functions while function of fuzzy logic engine to infer the proper control actions based on given fuzzy rules. Under defuzzification, control actions translated into crisp values by using normalized membership functions [17], [18]. In this paper defuzzification of output signal is done by using centroid method. Fuzzy based Controller has been designed by taking generator speed and its derivative as input while angle alpha as output. The fuzzy membership functions of these variables are as shown

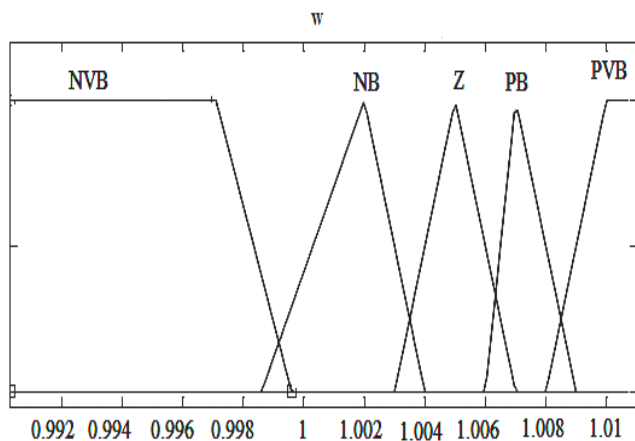

Fig3. input membership function of  $\omega$

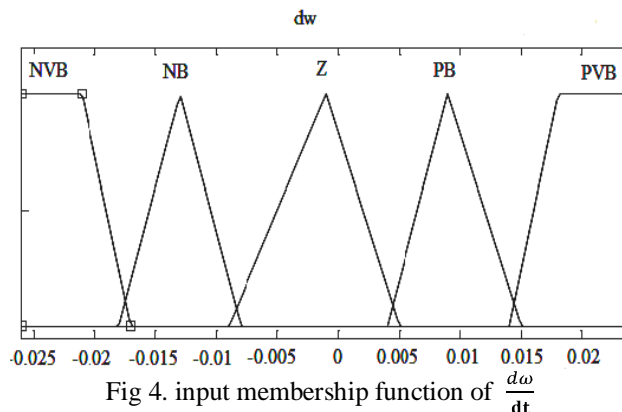

Fig 4. input membership function of  $\frac{d\omega}{dt}$

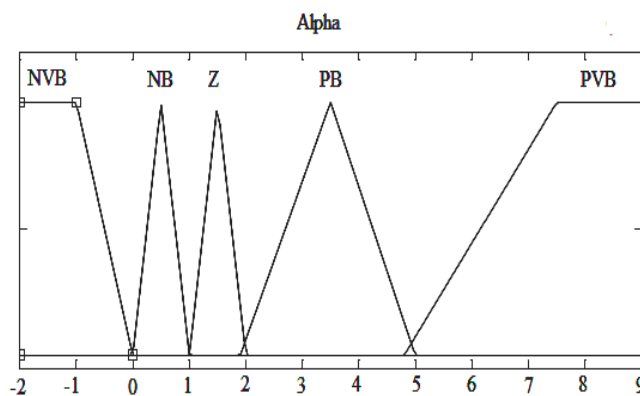

Fig 5. output membership function of  $\alpha$

Rule based table on which fuzzy controller for STATCOM installed on two machine systems is designed as given.

Table 1: Fuzzy Rules

| $\omega$<br>$d\omega/dt$ | NVB | NB | Z  | PB | PVB |
|--------------------------|-----|----|----|----|-----|
| NVB                      | nb  | nb | nb | nb | nb  |
| NB                       | nb  | nb | nb | nb | nb  |
| Z                        | nb  | nb | z  | pb | pb  |
| PB                       | pb  | pb | pb | pb | pb  |
| PVB                      | pb  | pb | pb | pb | pb  |

The logic behind rule can be easily derived. For example

R1: if  $\omega$  is **positive big** and  $d\omega$  is **positive very big** than firing angle  $\alpha$  is positive big.

R2: if  $\omega$  is **positive big** and  $d\omega$  is **positive big** than firing angle  $\alpha$  is positive big

The logic is that when frequency is high and it's rising fast, the system is in critical condition because the input mechanical power of generators is more than output electrical power. Therefore the STATCOM should inject big capacitive current into the network hence alpha should be small [19]. By this action the transmittable power capacity of the line on which STATCOM installed will be increased and the transient stability will be improved. Other conditions can be analysed in a similar way.

IV. SIMULATION MODEL

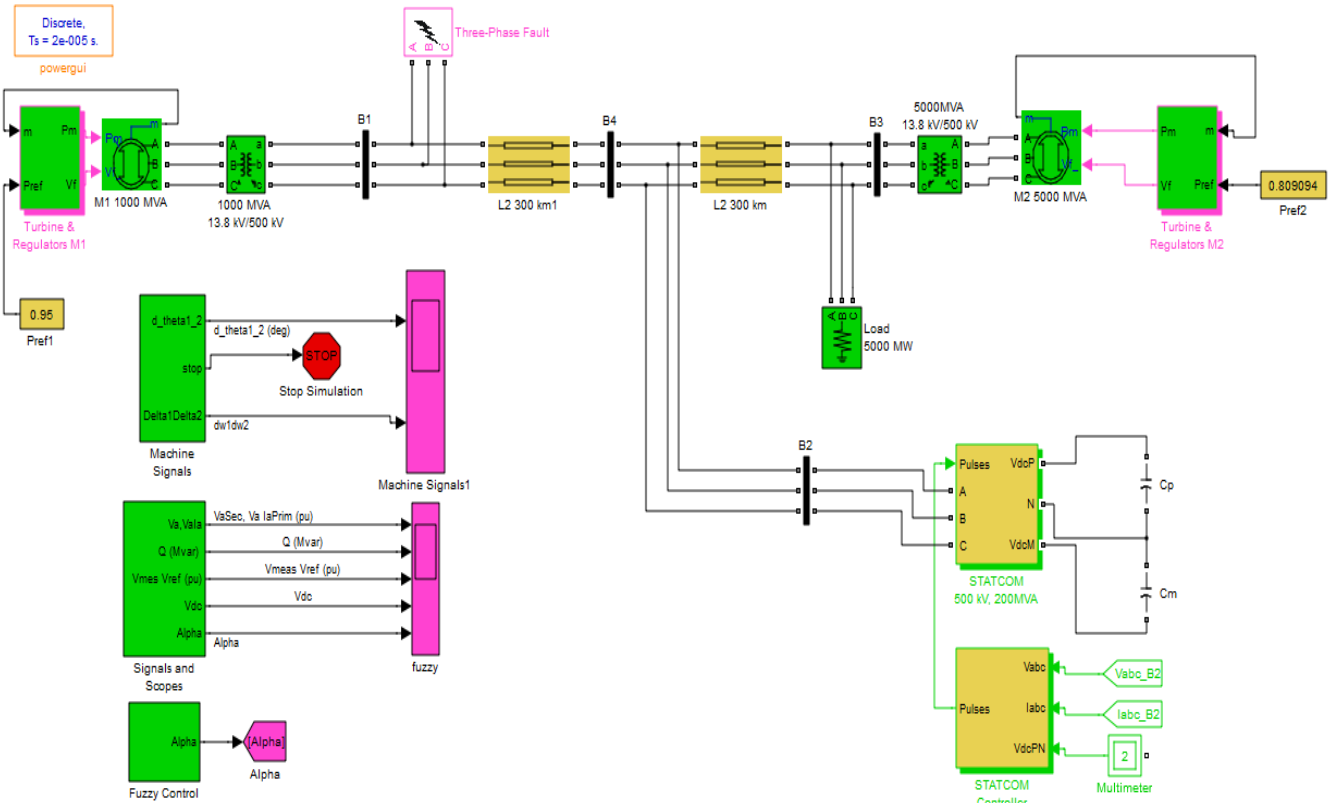

Fig 6. Simulink Diagram of STATCOM installed on Two Machine system

Simulink Model of two machines (M1 & M2) system is shown in Fig 6. Each machine equipped with a Governor, excitation system and Power system stabilizer. These components are included in Turbine & Regulator1 and Turbine & Regulator 2. Both machine connected through a 500 kv, 700km transmission line. Resistive load of 5000MW connected on Machine M2 side. GTO based STATCOM having rating of 200 MVA connected at midpoint of transmission line. Given simulation model run for under discrete mode with sample time (Ts) set at  $20 \times 10^{-6}$  sec.

V. SIMULATION RESULTS

A three phase fault having clearing time of 0.1 sec is given at 0.6 sec. System installed without STATCOM becomes unstable after fault. Now System is installed with PI based or fuzzy based STATCOM and fault having clearing time of 0.1 sec is given, system becomes stable after fault as shown by swing curve.

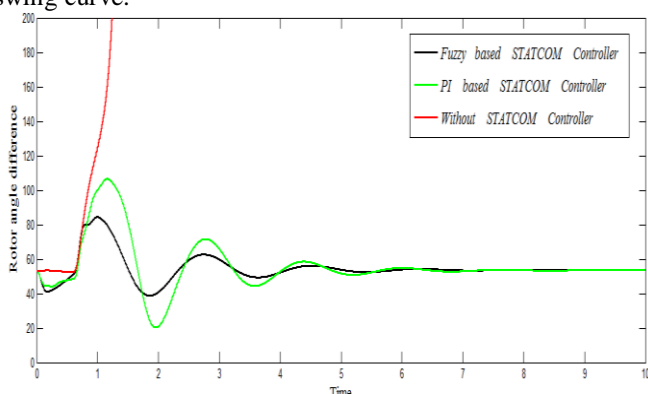

Fig 7. Rotor angle difference with time.

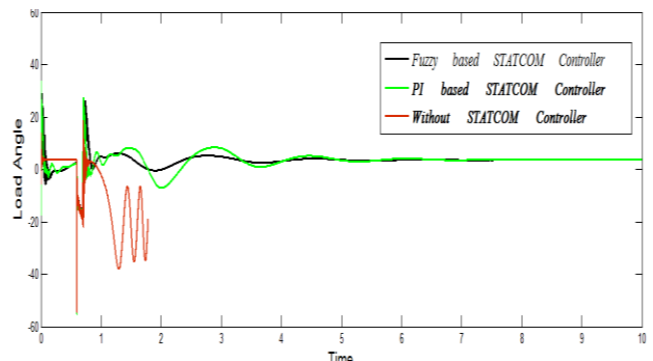

Fig 8. Load angle with time.

From Fig 7 & Fig 8 it's clear that fuzzy based STATCOM controller is more successful in damping of rotor angle and Load angle variation as compared to PI based STATCOM.

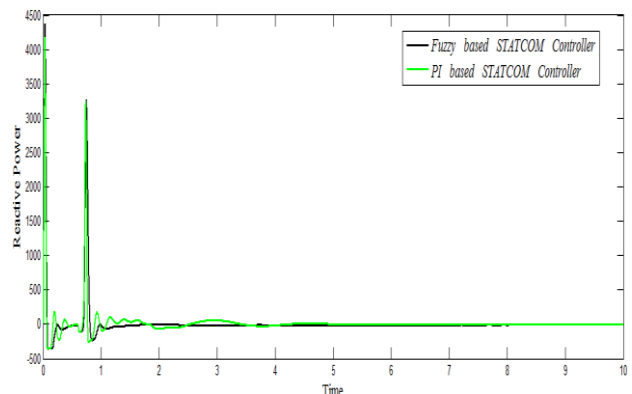

Fig 9. Reactive Power with time

Fig.9 shows comparison between reactive power of fuzzy based and PI based STATCOM controller.

# Transient Stability Improvement of Two Machine System using Fuzzy Controlled STATCOM

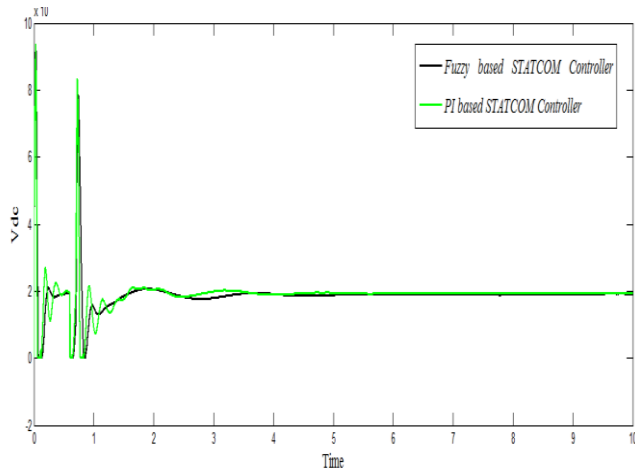

Fig 10. Variation of Vdc with respect to time.

Fig 10 shows the comparison between Vdc (voltage across Capacitor) of Fuzzy based STATCOM and conventional PI based STATCOM with time

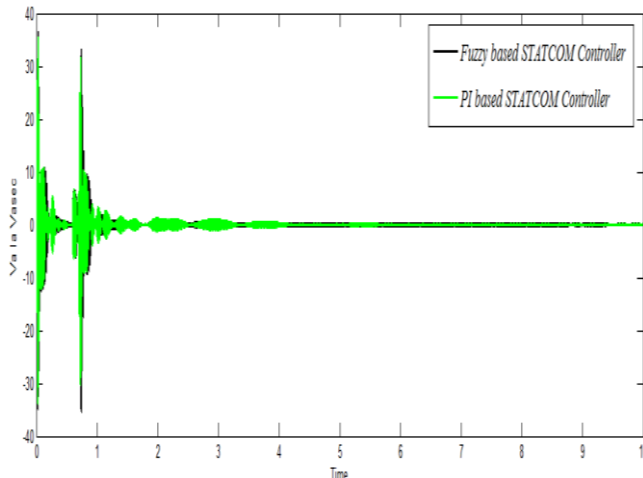

Fig 11. Variation of Vasec VaIa with time.

Fig 11 shows the comparison between voltage, current of bus B2 and transformer secondary voltage of Fuzzy based and PI based static synchronous compensator with time.

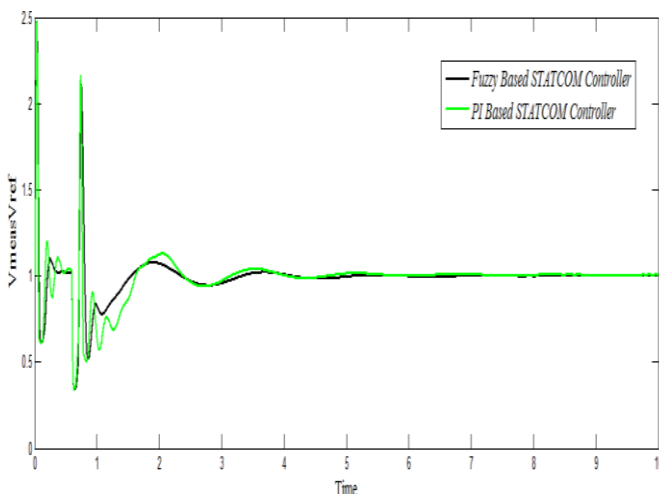

Fig 12. Variation of Vmeas Vref with time

Fig 12 shows the comparison between measured voltage (Vmeas) and reference voltage (Vref) of Fuzzy based STATCOM and PI based STATCOM with time. Fig 13.

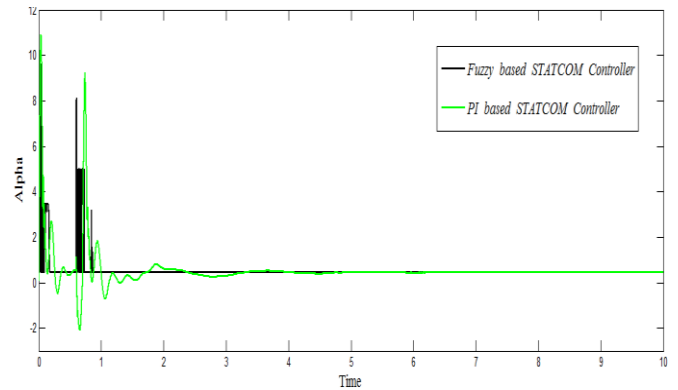

Fig 13. Alpha with time.

Fig 13 shows the comparison between angle Alpha of voltage source converter of fuzzy based STATCOM controller and PI based STATCOM with time.

## VI. CONCLUSION

In This Paper, Mamdani based fuzzy logic controller is successfully designed to control the STATCOM for improving transient stability of the power system. Controller inputs are chosen carefully to provide better damping to the system and its range are determined by the simulation results of fuzzification process. This control strategy is compared with conventional PI based STATCOM controller for two machine system. Simulation results indicate that fuzzy based STATCOM controller provides better transient stability as compared to PI based STATCOM controller for two machine system.

## VII. APPENDIX

Data for various components used in matlab simulink model of Fig 6 are as follows:

Generator Parameters: M1 =1000 MVA, M2=5000 MVA  
 $V = 13.8$  KV,  $f = 60$  Hz,  $X_d = 1.305$ ,  $X_d' = 0.296$ ,  
 $X_d'' = 0.252$ ,  $X_q = 0.474$ ,  $X_q' = 0.243$ ,  $X = 0.18$ ,  $H = 3.7$   
 Transformer Parameters: T1=1000MVA, T2=5000MVA  
 $13.8/500$  KV,  $R_m = L_m = 500$  ohm  
 Transmission Line Parameters per km:  $R_1 = 0.01755 \Omega$ ,  
 $R_0 = 0.2758 \Omega$ ,  $L_1 = 0.8737$ mH,  $L_0 = 3.22$ mH,  $C_1 = 13.33$ nF,  
 $C_2 = 8.297$ nF.  
 STATCOM: 500KV, 200MVA,  $V_{ref} = 1$  V,  $T_s = 20 \times 10^{-6}$   
 $C_p = C_m = 5000 \times 10^{-6}$   
 Science writers is [9].

## REFERENCES

- [1] Kundur Prabha, "Power system stability and control." McGraw-Hill, 1994 .
- [2] Cong, L. "Coordinated control of Generator excitation and STATCOM for Rotor angle stability and voltage regulation enhancement of power systems." IEE Proceedings on Generation & Transmission and Distribution, 149(2), pp 659-666, Feb 2003.
- [3] Hingorani and N.G. Gyungyi, "Understanding FACTS Devices." IEEE Press, 2000.
- [4] Spista.V, "Design of a Robust State Feedback Controller for a STATCOM Using Zero Set Concept", IEEE transactions on Power delivery, 25(1), pp 456-467, Jan 2010.
- [5] Haque, M.H. "Improvement of first swing stability limit by utilizing full benefit of shunt FACTS devices", IEEE transactions on Power Systems 19(4), pp 1894-1902 , Nov 2004.
- [6] Singh.B, "Static Synchronous compensators (STATCOM). A review", IET transaction on Power electronics, 2(4), pp 297-324, July 2009
- [7] Kumar Sahoo, A, "Modeling and simulation of 48-pulse VSC based STATCOM using simulink's power system blockset," India

- International Conference on Power Electronics (IICPE), Chennai, pp 303-308, Dec 2006.
- [8] Keyou Wang, "Power System voltage Regulation via STATCOM Internal Nonlinear Control", IEEE Transactions on Power Systems, 26(3), pp-1252-1262, Aug 2011.
- [9] Padiyar, K.R. "HVDC Power Transmission systems." 2 edition, new age international publishers.
- [10] Huang Shao-Ping, "Modeling and dynamic Simulation of GTO-Based STATCOM," International Conference on Electrical and Control Engineering (ICECE), Wuhan, pp 1293-1296, June 2010.
- [11] Tan, Y.L "Analysis of line compensation by Shunt -connected FACTS controllers: a comparison between SVC and STATCOM", IEEE proceedings on Power Engineering Review, 19(8), pp 57-58, Aug 1999.
- [12] Chun Li, "Design of a rule based Controller for STATCOM" 24<sup>th</sup> Annual Conference of the IEEE, Aachen, pp 467-472, Aug 2002.
- [13] M.Kazerani, "Mid-point sitting of facts devices in transmission lines," IEEE transaction on power delivery, 12(4), pp-1717-1722, Oct 1997.
- [14] Albarsi, F.A. "Performance Comparison of Distance Protection Schemes for shunt-Facts Compensated Transmission Lines." IEEE transactions on Power delivery, 22(4), pp 2116-2125, Oct 2007.
- [15] Mohaghegi, S. "An adaptive Mamdani fuzzy logic based Controller for a static compensator in a multimachine power system", Proceedings of the 13th International Conference on Intelligent Systems Applications to Power Systems, Arlington, VA, pp 6, Feb 2006.
- [16] Zolghardi, "Power System Transient Stability Improvement using Fuzzy Controlled STATCOM", International Conference on Power System Technology, Chongqing, pp 1-6, Feb 2007.
- [17] Timothy J. Ross, "Fuzzy logic with engineering applications"- John Wiley & Sons, Ltd
- [18] Ajami, A. "Application of a Fuzzy Controller for Transient Stability Enhancement of AC Transmission System by STATCOM.", International Joint Conference on SICE-ICASE, Busan, pp 6059 - 6063, Feb 2007.
- [19] A.Ghafouri, "Fuzzy Controlled STATCOM for improving the Power System Transient Stability." 39<sup>th</sup> North American Power Symposium, 2007, Las Cruces, NM, pp 212-216, Dec 2007.

**Surinder Chauhan** was born in Kurukshetra, Haryana, India in 1985. He received the B.Tech degree in Electrical Engineering from kurukshetra University, Kurukshetra, Haryana India. Now he is pursuing M.E (Power system and electrical drives) from Department of Electrical and Instrumentation Engineering, Thapar University, Patiala Punjab, India .

**Vikram** was born on September 28, 1983 in India. He received B.E (Electrical) from APJ College of Engineering, Gurgaon, India in 2006 and M.Tech. in Control System from N.I.T. Kurukshetra (India) in 2009. He is working as a Lecturer in the Department of Electrical & Instrumentation Engineering at Thapar University Patiala since June 2009 and pursuing his Ph.D from the same department. His areas of interest include optimal control, artificial intelligence and process control.

**Shakti Singh** was born in Saharanpur, UP, India in 1980. He received his B.E. degree from Madan Mohan Malviya Engineering college, Gorakhpur and M.Tech. degree in Energy and Environment Management from Indian Institute of Technology, New Delhi. Currently he is working as an Assistant Professor in the Department of Electrical and Instrumentation Engineering, Thapar University, Patiala, Punjab, India. He is currently working towards the Ph.D. degree from Thapar University. His areas of research interest include, renewable energy sources, and distributed generation.